

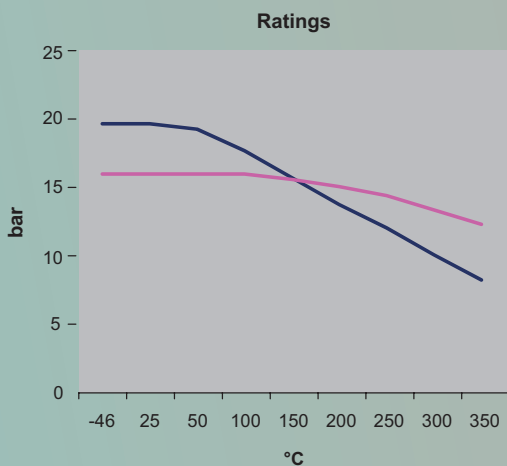

Dimensionamenti  
Design ANSI B16.34 / EN 12569 / API 608 / EN 17292  
ASME VIII DIV.1 / EN 12516-1

Estremità flangiate  
Flanged ends ANSI B 16.5 CL.150  
EN 1092-1 PN 16  
DIN 2633 PN 16

Collaudo  
Testing ANSI B16.104  
API 598  
EN 12266-I  
ISO 5208  
BS 6755-I

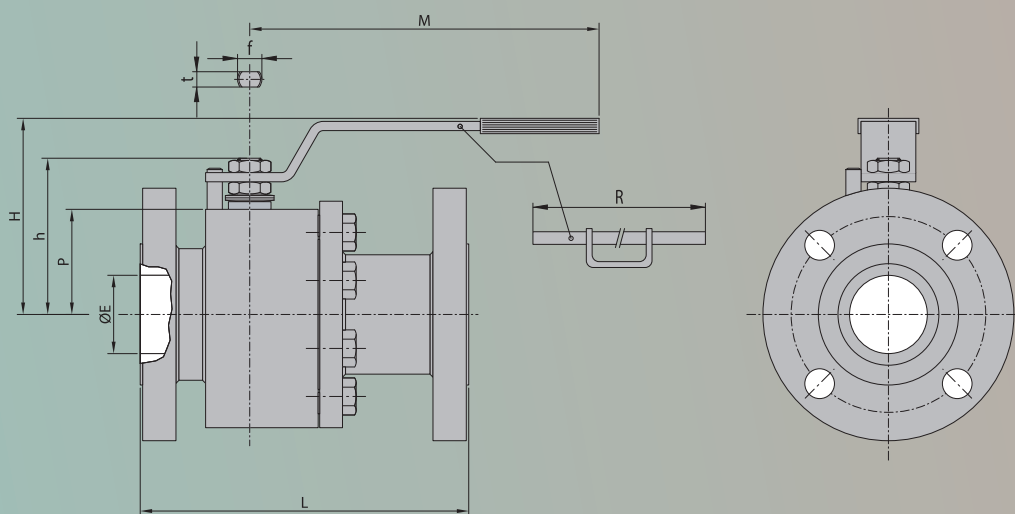
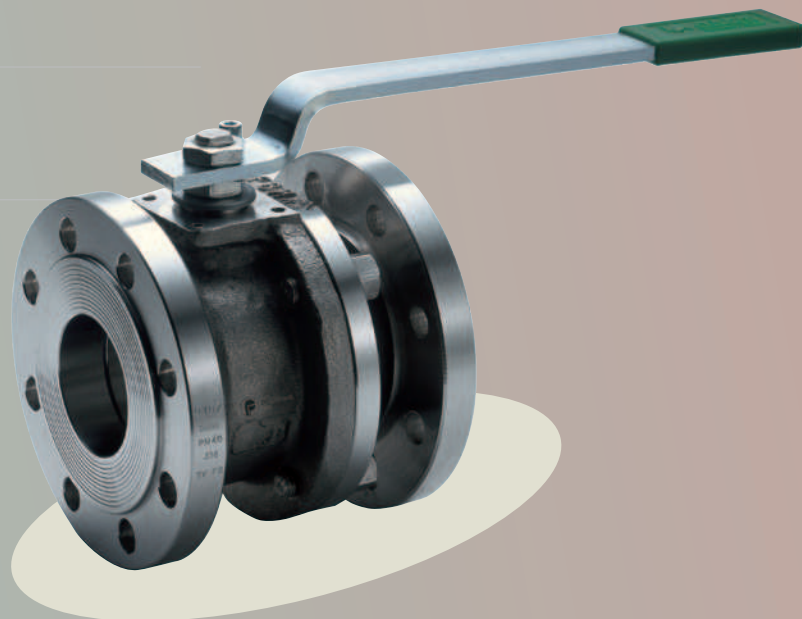

### Dimensioni - outline dimensions

DN	15	20	25	32	40	50	65	80	100	150
Ø"	1/2"	3/4"	1"	1 1/4"	1 1/2"	2"	2 1/2"	3"	4"	6"
ØE	14	19	24	29	38	51	64	76	102	152
L	108	117	127	140	165	178	190	203	229	394
M	145	145	180	180	275	275	380	380	440	— <sup>(1)</sup>
R	—	—	—	—	—	—	—	—	500	800
H	64	66	85	90	118	128	139	144	200	265
h	52	55	70	73	96	103	122	128	157	220
P	33	36	43	48	63	68.5	82	88.5	111	153
F/t	10/6	10/6	12/8	12/8	16/10	16/10	22/14	22/14	30/18	45/30
Kg	2.5	3	5.5	7	11	17	22	26	48	71
ISO5211	F03	F03	F03	F03	F05	F05	F07	F07	F10	F14

<sup>(1)</sup> È raccomandato riduttore manuale - Manual gear recommended

# VALVOLE A SFERA FLOTTANTE A SEGGI METALLICI

## METAL SEATED FLOATING BALL VALVES

BI-DIRECTIONAL

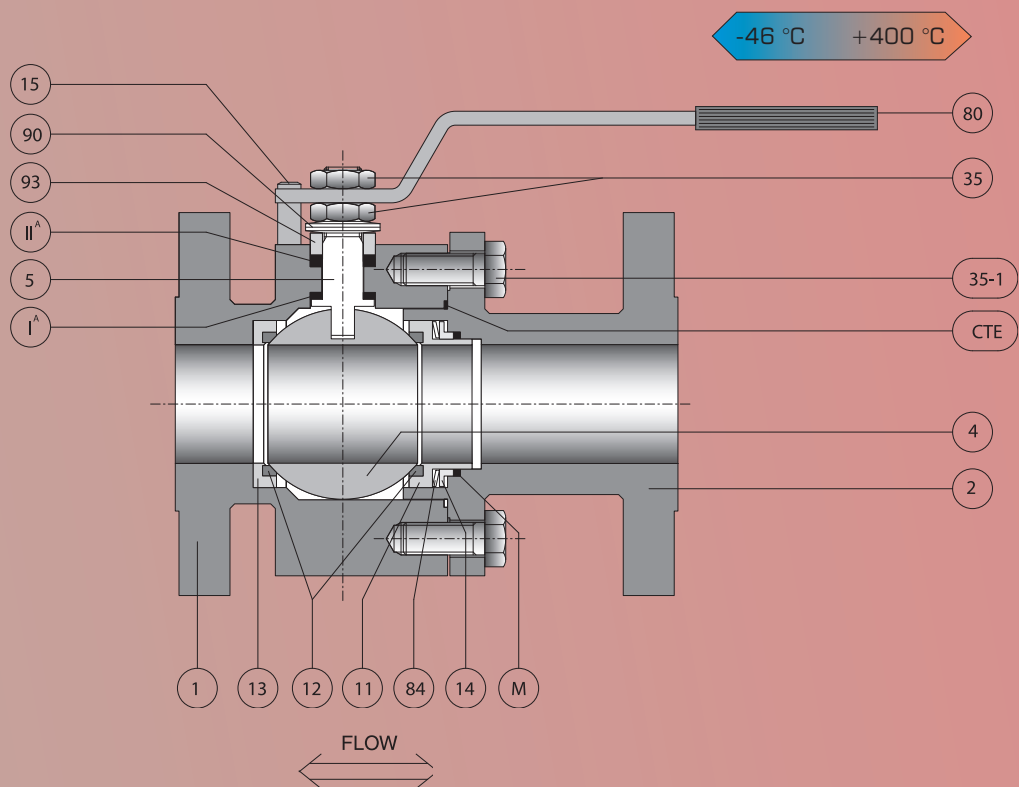

TA-LUFT  
APPROVED  
(CON PROLUNGA 100 MM)  
C/W 100 MM STEM ELONGATION

FIRE-SAFE CERTIFIED  
API 607 V ED  
ISO 10497

CE  
97/23/CE "PED"  
CAT III

II 2 GD c T6 X  
94/9/CE "ATEX"

### Materiali base - base materials

CTE	Guarn. Corpo/Terminale	Body connector gasket	Grafoil	Grafoil	Grafoil
M	Guarn. Retroseggio	Backseat gasket	Grafoil	Grafoil	Grafoil
II <sup>A</sup>	Guarnizione Secondaria	Secondary Stem seal	Grafoil	Grafoil	Grafoil
I <sup>A</sup>	Guarnizione Primaria	Primary stem seal	Grafoil	Grafoil	Grafoil
93	Premi Baderna	Gland	304 S.S.	304 S.S.	304 S.S.
90	Molle Stelo	Stem spring	UNS S30100	UNS S30100	UNS S30100
84	Molle Seggio	Seat spring	UNS S30100	UNS S30100	UNS S30100
80	Leva	Handle	Fe37 UNI 7070	Fe37 UNI 7070	Fe37 UNI 7070
35-1	Bulloneria Corpo/Terminale	Body/Connector Bolts	A193 B7 A194 Gr.2H	A193 B8 A 194 Gr.8	A193 B8M A194 Gr.Gr.8M
35	Dadi Stelo	Nut	304 S.S.	304 S.S.	304 S.S.
15	Fermo Leva	Lever stopper	Gr. 8.8 UNI 3740	Gr. 8.8 UNI 3740	Gr. 8.8 UNI 3740
14	Premigrafoil	Compression ring	A479 Tp.316	A479 Tp.316	A479 Tp.316
13	Cassetto Corpo	Body seat holder	A479 Tp.316	A479 Tp.316	A479 Tp.316
12	Seggio	Seat	PENTAFITE ST6 WC/CRC	PENTAFITE ST6 WC/CRC	PENTAFITE ST6 WC/CRC
11	Cassetto Terminale	Connector seat holder	A479 Tp.316	A479 Tp.316	A479 Tp.316.
5	Stelo	Stem	13% Cr. A564 Tp.630 (17/4PH)	A564 Tp.630 (17/4PH)	A564 Tp.630 (17/4PH)
-	Riporto Sfera	Ball coating	HTC/HCR ST6 WC/CRC	HTC/HCR ST6 WC/CRC	HTC/HCR ST6 WC/CRC
4	Sfera	Ball	316 S.S.	316 S.S.	316 S.S.
2	Terminale	Connector	A105/A216 WCB	A479 Tp.304/A351 CF8	A479 Tp.316/A351 CF8M
1	Corpo	Body	A105/A216 WCB	A479 Tp.304/A351 CF8	A479 Tp.316/A351 CF8M

P. No. Parte - Part Name

Materiale - Material

Altri materiali disponibili su richiesta - Other materials are available on request  
Altre estremità disponibili su richiesta - Other end connections available on request

HTC = Nitruri di Titanio (Titanium Nitrides); HCR = Nitruri di Cromo (Chrome Nitrides); ST6 = Stellite 6 Detonation Gun/HVOF  
WC = Carburi di Tungsteno (Tungsten Carbides Detonation Gun/HVOF); CRC = Carburi di Cromo (Chrome Carbides Detonation Gun/HVOF)